



CCSDS

The Consultative Committee for Space Data Systems

Recommendation for Space Data System Standards

**PROXIMITY-1 SPACE
LINK PROTOCOL—
PHYSICAL LAYER**

RECOMMENDED STANDARD

CCSDS 211.1-B-4

BLUE BOOK

December 2013

Recommendation for Space Data System Standards

**PROXIMITY-1 SPACE
LINK PROTOCOL—
PHYSICAL LAYER**

RECOMMENDED STANDARD

CCSDS 211.1-B-4

BLUE BOOK
December 2013

AUTHORITY

Issue:	Recommended Standard, Issue 4
Date:	December 2013
Location:	Washington, DC, USA

This document has been approved for publication by the Management Council of the Consultative Committee for Space Data Systems (CCSDS) and represents the consensus technical agreement of the participating CCSDS Member Agencies. The procedure for review and authorization of CCSDS documents is detailed in *Organization and Processes for the Consultative Committee for Space Data Systems* (CCSDS A02.1-Y-3), and the record of Agency participation in the authorization of this document can be obtained from the CCSDS Secretariat at the address below.

This document is published and maintained by:

CCSDS Secretariat
Space Communications and Navigation Office, 7L70
Space Operations Mission Directorate
NASA Headquarters
Washington, DC 20546-0001, USA

STATEMENT OF INTENT

The Consultative Committee for Space Data Systems (CCSDS) is an organization officially established by the management of its members. The Committee meets periodically to address data systems problems that are common to all participants, and to formulate sound technical solutions to these problems. Inasmuch as participation in the CCSDS is completely voluntary, the results of Committee actions are termed **Recommended Standards** and are not considered binding on any Agency.

This **Recommended Standard** is issued by, and represents the consensus of, the CCSDS members. Endorsement of this **Recommendation** is entirely voluntary. Endorsement, however, indicates the following understandings:

- o Whenever a member establishes a CCSDS-related **standard**, this **standard** will be in accord with the relevant **Recommended Standard**. Establishing such a **standard** does not preclude other provisions which a member may develop.
- o Whenever a member establishes a CCSDS-related **standard**, that member will provide other CCSDS members with the following information:
 - The **standard** itself.
 - The anticipated date of initial operational capability.
 - The anticipated duration of operational service.
- o Specific service arrangements shall be made via memoranda of agreement. Neither this **Recommended Standard** nor any ensuing **standard** is a substitute for a memorandum of agreement.

No later than three years from its date of issuance, this **Recommended Standard** will be reviewed by the CCSDS to determine whether it should: (1) remain in effect without change; (2) be changed to reflect the impact of new technologies, new requirements, or new directions; or (3) be retired or canceled.

In those instances when a new version of a **Recommended Standard** is issued, existing CCSDS-related member standards and implementations are not negated or deemed to be non-CCSDS compatible. It is the responsibility of each member to determine when such standards or implementations are to be modified. Each member is, however, strongly encouraged to direct planning for its new standards and implementations towards the later version of the Recommended Standard.

FOREWORD

Attention is drawn to the possibility that some of the elements of this document may be the subject of patent rights. CCSDS shall not be held responsible for identifying any or all such patent rights.

Through the process of normal evolution, it is expected that expansion, deletion, or modification of this document may occur. This Recommended Standard is therefore subject to CCSDS document management and change control procedures, which are defined in *Organization and Processes for the Consultative Committee for Space Data Systems* (CCSDS A02.1-Y-3). Current versions of CCSDS documents are maintained at the CCSDS Web site:

<http://www.ccsds.org/>

Questions relating to the contents or status of this document should be addressed to the CCSDS Secretariat at the address indicated on page i.

At time of publication, the active Member and Observer Agencies of the CCSDS were:

Member Agencies

- Agenzia Spaziale Italiana (ASI)/Italy.
- Canadian Space Agency (CSA)/Canada.
- Centre National d'Etudes Spatiales (CNES)/France.
- China National Space Administration (CNSA)/People's Republic of China.
- Deutsches Zentrum für Luft- und Raumfahrt (DLR)/Germany.
- European Space Agency (ESA)/Europe.
- Federal Space Agency (FSA)/Russian Federation.
- Instituto Nacional de Pesquisas Espaciais (INPE)/Brazil.
- Japan Aerospace Exploration Agency (JAXA)/Japan.
- National Aeronautics and Space Administration (NASA)/USA.
- UK Space Agency/United Kingdom.

Observer Agencies

- Austrian Space Agency (ASA)/Austria.
- Belgian Federal Science Policy Office (BFSPPO)/Belgium.
- Central Research Institute of Machine Building (TsNIIMash)/Russian Federation.
- China Satellite Launch and Tracking Control General, Beijing Institute of Tracking and Telecommunications Technology (CLTC/BITTT)/China.
- Chinese Academy of Sciences (CAS)/China.
- Chinese Academy of Space Technology (CAST)/China.
- Commonwealth Scientific and Industrial Research Organization (CSIRO)/Australia.
- Danish National Space Center (DNSC)/Denmark.
- Departamento de Ciência e Tecnologia Aeroespacial (DCTA)/Brazil.
- European Organization for the Exploitation of Meteorological Satellites (EUMETSAT)/Europe.
- European Telecommunications Satellite Organization (EUTELSAT)/Europe.
- Geo-Informatics and Space Technology Development Agency (GISTDA)/Thailand.
- Hellenic National Space Committee (HNSC)/Greece.
- Indian Space Research Organization (ISRO)/India.
- Institute of Space Research (IKI)/Russian Federation.
- KFKI Research Institute for Particle & Nuclear Physics (KFKI)/Hungary.
- Korea Aerospace Research Institute (KARI)/Korea.
- Ministry of Communications (MOC)/Israel.
- National Institute of Information and Communications Technology (NICT)/Japan.
- National Oceanic and Atmospheric Administration (NOAA)/USA.
- National Space Agency of the Republic of Kazakhstan (NSARK)/Kazakhstan.
- National Space Organization (NSPO)/Chinese Taipei.
- Naval Center for Space Technology (NCST)/USA.
- Scientific and Technological Research Council of Turkey (TUBITAK)/Turkey.
- South African National Space Agency (SANSA)/Republic of South Africa.
- Space and Upper Atmosphere Research Commission (SUPARCO)/Pakistan.
- Swedish Space Corporation (SSC)/Sweden.
- Swiss Space Office (SSO)/Switzerland.
- United States Geological Survey (USGS)/USA.

DOCUMENT CONTROL

Document	Title	Date	Status
CCSDS 211.0-B-1	Proximity-1 Space Link Protocol	October 2002	Original issue, superseded
CCSDS 211.1-B-1	Proximity-1 Space Link Protocol— Physical Layer	April 2003	Superseded
CCSDS 211.1-B-2	Proximity-1 Space Link Protocol— Physical Layer	May 2004	Superseded
CCSDS 211.1-B-3	Proximity-1 Space Link Protocol— Physical Layer, Recommended Standard, Issue 3	March 2006	Superseded
CCSDS 211.1-B-4	Proximity-1 Space Link Protocol— Physical Layer, Recommended Standard, Issue 4	December 2013	Current issue: This update includes several improvements and clarifications, accomplishing better alignment and consistency with the other Proximity-1 Blue Books.
CCSDS 211.1-B-4 EC 1	Editorial change 1	January 2018	Repairs broken cross reference; improves formatting in Table of Contents.

NOTE – Changes from the current issue are too extensive to permit markup.

CONTENTS

<u>Section</u>	<u>Page</u>
1 INTRODUCTION.....	1-1
1.1 PURPOSE.....	1-1
1.2 SCOPE.....	1-1
1.3 APPLICABILITY.....	1-1
1.4 RATIONALE.....	1-2
1.5 CONVENTIONS AND DEFINITIONS.....	1-2
1.6 REFERENCES	1-5
2 OVERVIEW.....	2-1
2.1 PHYSICAL LAYER OVERVIEW	2-1
2.2 DATA LINK LAYER OVERVIEW	2-1
3 GENERAL REQUIREMENTS FOR THE PHYSICAL LAYER	3-1
3.1 RADIO EQUIPMENT.....	3-1
3.2 PHYSICAL LAYER FUNCTIONS	3-1
3.3 CONTROLLED COMMUNICATIONS CHANNEL PROPERTIES	3-5
3.4 PERFORMANCE REQUIREMENTS	3-9
ANNEX A PROTOCOL IMPLEMENTATION CONFORMANCE STATEMENT PROFORMA (NORMATIVE).....	A-1
ANNEX B SECURITY, SANA, AND PATENT CONSIDERATIONS (INFORMATIVE)	B-1
ANNEX C INFORMATIVE REFERENCES (INFORMATIVE)	C-1
ANNEX D ABBREVIATIONS AND ACRONYMS (INFORMATIVE).....	D-1

Figure

1-1 Proximity-1 Rate Terminology.....	1-5
2-1 Simplified Overview of Proximity-1 Layers	2-2
3-1 Control Variables, Signals, and Data Transfers.....	3-2
3-2 Oscillator Phase Noise.....	3-10
3-3 Discrete Lines Template for the Transmitter (Normalized Power in dBc vs. Normalized Frequency: $(f-f_c)/A$)	3-10

CONTENTS (continued)

<u>Table</u>	<u>Page</u>
3-1 Categories of Radio Equipment Contained on Proximity-1 Link Elements.....	3-1
3-2 Control Variables for Transmitter	3-3
3-3 Control Variables for Receiver	3-4
3-4 Proximity-1 Channel Assignments 0 through 7 (Frequencies in MHz)	3-7
A-1 Major Capabilities	A-4

1 INTRODUCTION

1.1 PURPOSE

The purpose of this Recommended Standard is to specify Physical Layer procedures used with the Proximity-1 Data Link Layer (references [3] and [2]). Proximity space links are defined to be short-range, bi-directional, fixed or mobile radio links, generally used to communicate among probes, landers, rovers, orbiting constellations, and orbiting relays. These links are characterized by short time delays, moderate (not weak) signals, and short, independent sessions.

1.2 SCOPE

This Recommended Standard defines the Proximity-1 Space Link Protocol Physical Layer. The specification for the channel connection process, provision for frequency bands and assignments, hailing channel, polarization, modulation, data rates, and performance requirements are defined in this document.

Currently, the Physical Layer only defines operations at UHF frequencies for the Mars environment.

The Data Link Layer is defined in the two separate CCSDS Recommended Standards entitled, *Proximity-1 Space Link Protocol—Coding and Synchronization Sublayer* (reference [2]), and *Proximity-1 Space Link Protocol—Data Link Layer* (reference [3]).

This Recommended Standard does not specify

- a) individual implementations or products;
- b) implementation of service interfaces within real systems;
- c) the methods or technologies required to perform the procedures; or
- d) the management activities required to configure and control the protocol.

1.3 APPLICABILITY

This Recommended Standard applies to the creation of Agency standards and to future data communications over space links between CCSDS Agencies in cross-support situations. It applies also to internal Agency links where no cross-support is required. It includes specification of the services and protocols for inter-Agency cross support. It is neither a specification of, nor a design for, systems that may be implemented for existing or future missions.

The Recommended Standard specified in this document is to be invoked through the normal standards programs of each CCSDS Agency and is applicable to those missions for which cross support based on capabilities described in this Recommended Standard is anticipated. Where mandatory capabilities are clearly indicated in sections of the Recommended

Standard, they must be implemented when this document is used as a basis for cross support. Where options are allowed or implied, implementation of these options is subject to specific bilateral cross support agreements between the Agencies involved.

1.4 RATIONALE

The CCSDS believes it is important to document the rationale underlying the recommendations chosen, so that future evaluations of proposed changes or improvements will not lose sight of previous decisions. Concept and rationale behind the decisions that formed the basis for Proximity-1 are documented in the CCSDS Proximity-1 Space Link Protocol Green Book, reference [C1].

1.5 CONVENTIONS AND DEFINITIONS

1.5.1 DEFINITIONS

1.5.1.1 Terms from the Open Systems Interconnection (OSI) Basic Reference Model

This Recommended Standard makes use of a number of terms defined in reference [1]. In this Recommended Standard those terms are used in a generic sense, i.e., in the sense that those terms are generally applicable to any of a variety of technologies that provide for the exchange of information between real systems. Those terms are as follows:

- a) connection;
- b) Data Link Layer;
- c) Physical Layer;
- d) protocol data unit;
- e) real system;
- f) service;
- g) service data unit.

1.5.1.2 Terms Defined in This Recommended Standard

For the purposes of this Recommended Standard, the following definitions also apply. Many other terms that pertain to specific items are defined in the appropriate sections.

caller and responder: Initiator and receiver, respectively, in a Proximity space link session.

NOTE – A **caller transceiver** is the initiator of the link establishment process and manager of negotiation (if required) of the session. A **responder transceiver** typically receives link establishment parameters from the caller. The caller initiates communication between itself and a responder on a prearranged communications channel with predefined controlling parameters. As necessary, the caller and responder may negotiate the controlling parameters for the session (at some level between fully controlled and completely adaptive).

forward link: That portion of a Proximity space link in which the caller transmits and the responder receives (typically a command link). The term ‘forward’ is used in association with any parameters referring to the forward link.

hailing: The persistent activity used to establish a Proximity link by a caller to a responder in either full or half duplex. It does not apply to simplex operations.

hailing channel: The forward and return frequency pairs that a caller and responder use to establish physical link communications.

physical channel: The RF channel upon which the stream of channel symbols is transferred over a space link in a single direction.

PLTU: Proximity Link Transmission Unit, the data unit composed of the Attached Synchronization Marker, the Version-3 Transfer Frame, and the attached Cyclic Redundancy Check (CRC)-32.

Proximity link: A full-duplex, half-duplex, or simplex link for the transfer of data between Proximity-1 entities in a session.

return link: That portion of a Proximity space link in which the responder transmits and the caller receives (typically a telemetry link). The term ‘return’ is used in association with any parameters referring to the return link.

session: A dialog between two or more communicating Proximity link transceivers.

NOTE – A session consists of three distinct operational phases: session establishment, data services (which may include resynchronization and/or reconnect subphases), and session termination. Session termination can be coordinated (through the exchange of no-more-data-to-send directives), or, if communication is lost (inability to resynchronize or reconnect), the transceivers will eventually independently conclude the dialog is over.

space link: A communications link between transmitting and receiving entities, at least one of which is in space.

working channel: A forward and return frequency pair used for transferring User data/information frames (U-frames) and Protocol/supervisory frames (P-frames) during the data service and session termination phases.

1.5.2 NOMENCLATURE

1.5.2.1 NORMATIVE TEXT

The following conventions apply for the normative specifications in this Recommended Standard:

- a) the words ‘shall’ and ‘must’ imply a binding and verifiable specification;
- b) the word ‘should’ implies an optional, but desirable, specification;
- c) the word ‘may’ implies an optional specification;
- d) the words ‘is’, ‘are’, and ‘will’ imply statements of fact.

NOTE – These conventions do not imply constraints on diction in text that is clearly informative in nature.

1.5.2.2 INFORMATIVE TEXT

In the normative section of this document (section 3), informative text is set off from the normative specifications either in notes or under one of the following subsection headings:

- Overview;
- Background;
- Rationale;
- Discussion.

1.5.3 CONVENTIONS

Throughout this Recommended Standard, directive, parameter, variable, and signal names are presented with all upper-case characters; data-field and MIB-parameter names are presented with initial capitalization; values and state names are presented with predominantly lowercase italic characters.

In Proximity-1, data rate (R_d), coded symbol rate (R_{cs}) and channel symbol rate (R_{chs}) are used to denote respectively:

- the data rate of the bitstream composed by PLTUs and Idle data measured at the encoder input;
- the coded data rate measured at the interface between the Coding and Synchronization Sublayer and the Physical Layer; and
- the rate measured at the output of the transmitter.

The terms are used as shown in figure 1-1.

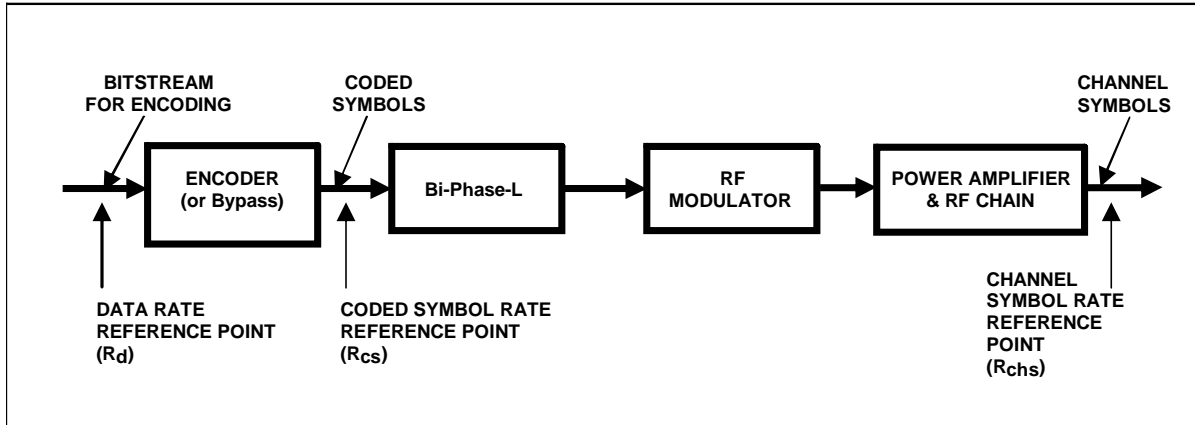

Figure 1-1: Proximity-1 Rate Terminology

With respect to the modulation scheme specified in 3.3.5.1, the following relationship applies for the purpose of the present standard:

$$R_{chs} = R_{cs}$$

1.6 REFERENCES

The following publications contain provisions which, through reference in this text, constitute provisions of this document. At the time of publication, the editions indicated were valid. All publications are subject to revision, and users of this document are encouraged to investigate the possibility of applying the most recent editions of the publications indicated below. The CCSDS Secretariat maintains a register of currently valid CCSDS publications.

- [1] *Information Technology—Open Systems Interconnection—Basic Reference Model: The Basic Model*. International Standard, ISO/IEC 7498-1:1994. 2nd ed. Geneva: ISO, 1994.
- [2] *Proximity-1 Space Link Protocol—Coding and Synchronization Sublayer*. Issue 2. Recommendation for Space Data System Standards (Blue Book), CCSDS 211.2-B-2. Washington, D.C.: CCSDS, December 2013.
- [3] *Proximity-1 Space Link Protocol—Data Link Layer*. Issue 5. Recommendation for Space Data System Standards (Blue Book), CCSDS 211.0-B-5. Washington, D.C.: CCSDS, December 2013.

2 OVERVIEW

2.1 PHYSICAL LAYER OVERVIEW

Proximity-1 is a bi-directional Space Link Layer protocol for use by space missions. It consists of a Physical Layer (the subject of this document) and a Data Link Layer (references [2] and [3]). This protocol has been designed to meet the requirements of space missions for efficient transfer of space data over various types and characteristics of Proximity space links.

Proximity-1 activities are divided between a send side and a receive side. The send side is concerned with the transmitted physical channel, and also with the acquisition of the received physical channel in order to establish a Proximity-1 link. The operation of the transmitter is state-driven. The receive side is concerned with the reception of data on the received physical channel: the input symbols stream and the protocol data units it contains. Once the receiver is turned on, its operation is modeless. It accepts and processes all valid local and remote directives and received service data units.

On the send side, the Physical Layer:

- accepts control variables from the MAC Sublayer of the Data Link Layer for control of the transceiver;
- accepts a coded symbols stream from the Coding & Synchronization Sublayer (reference [2]) of the Data Link Layer for modulation onto the radiated carrier.

On the receive side, the Physical Layer:

- provides status signals (CARRIER_ACQUIRED and SYMBOL_INLOCK_STATUS) to the MAC Sublayer of the Data Link Layer.

2.2 DATA LINK LAYER OVERVIEW

This subsection provides a brief overview of the Data Link Layer, with emphasis on the features relevant to the Physical Layer. For a fuller description of the overall Proximity-1 system, of the Data Link Layer and of its sublayers (see reference [3]).

On the send side, the Data Link Layer is responsible for providing the coded symbols to be transmitted by the Physical Layer. On the receive side, the Data Link Layer accepts the serial coded symbols stream output from the receiver in the Physical Layer and processes the Protocol Data Units contained in it.

Within the Data Link Layer, the Medium Access Control (MAC) Sublayer (reference [3]) and the Coding and Synchronization (C&S) Sublayer (reference [2]) have interfaces to the Physical Layer.

The Medium Access Control (MAC) Sublayer controls the establishment, maintenance, and termination of communications sessions for point-to-point communications between Proximity entities. It controls the operational state of the Data Link and Physical Layers, using control variables. It accepts Proximity-1 directives both from the local vehicle controller and across the Proximity link to control its operations. The MAC Sublayer is also responsible for the storage and distribution of the Management Information Base (MIB) parameters.

On the send side, the C&S Sublayer generates the output coded symbols stream, containing Proximity Link Transmission Units (PLTUs) and Idle data, which is delivered to the Physical Layer for modulation onto the radiated carrier. On the receive side, the C&S Sublayer accepts the incoming serial coded symbols stream from the Physical Layer and delimits each PLTU contained in the symbol stream.

Figure 2-1 gives a simplified view of the relationship of the Data Link Layer to the Physical Layer. (For a more detailed view of the Proximity-1 system, see reference [3].)

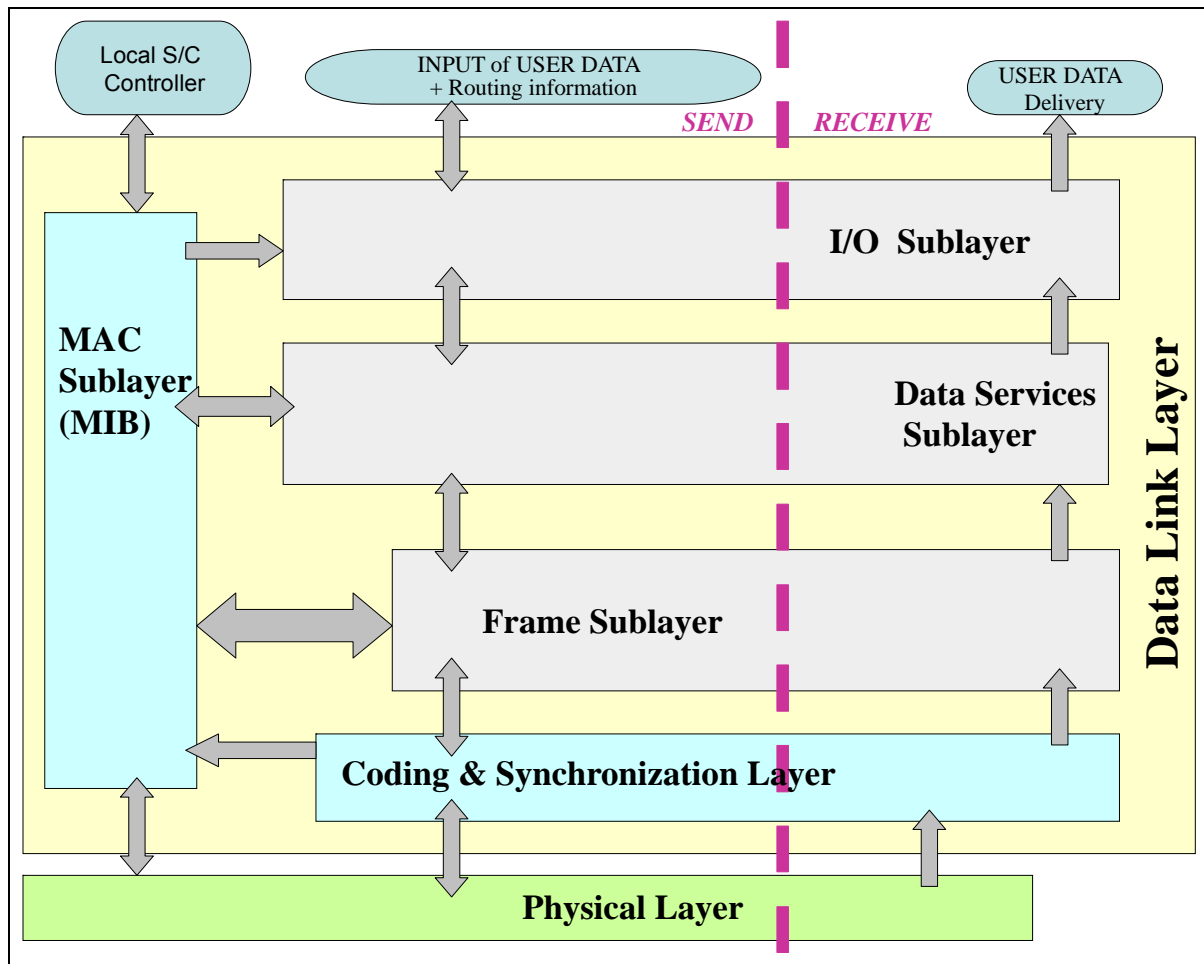

Figure 2-1: Simplified Overview of Proximity-1 Layers

3 GENERAL REQUIREMENTS FOR THE PHYSICAL LAYER

3.1 RADIO EQUIPMENT

3.1.1 OVERVIEW

The Proximity-1 Link system supports the communication and navigation needs between a variety of network elements, e.g., orbiters, landers, rovers, microprobes, balloons, aerobots, gliders. The categories of radio equipment in network elements (E1, E2,...) are listed in table 3-1.

3.1.2 COHERENCY REQUIREMENT

Link elements in category E2c (table 3-1), for which range and range-rate measurements are needed, shall have transmit/receive frequency coherency capability. (See 3.4.5 for Doppler tracking and acquisition requirements.)

Table 3-1: Categories of Radio Equipment Contained on Proximity-1 Link Elements

Category	Description
E1:	Elements with transmit-only capability.
E2:	Elements with transmit and receive capability.
E2n:	E2 elements with non-coherent mode only.
E2c:	E2 elements offering in addition transmit/receive frequency coherency capability.
E2d:	E2 elements with a descoped receiver capable of receiving an FSK modulated carrier. These elements transmit using PSK modulation.
NOTE – E2d radio equipment is intended to be used in microprobes. This option is not required for cross support.	

3.2 PHYSICAL LAYER FUNCTIONS

3.2.1 OVERVIEW

3.2.1.1 Physical Layer to Data Link Layer Interfaces

The prime function of the Physical Layer is to establish and maintain a communications channel upon which the data can flow. To enable a physical channel connection, the Physical Layer goes through a series of actions to establish a communications channel.

The Physical Layer accepts control variables (MODE, DUPLEX, TRANSMIT, MODULATION) from the MAC Sublayer of the Data Link Layer for control of the transceiver. Reference [3] contains the specification of the actions to establish, maintain and terminate a Proximity-1 communications session: the actions are specified in state tables and the control variables are defined. Requirements in 3.2.2 and 3.2.3, below, complement the specifications in reference [3].

Figure 3-1 shows the data and control flows between the Physical Layer and elements of the Data Link Layer.

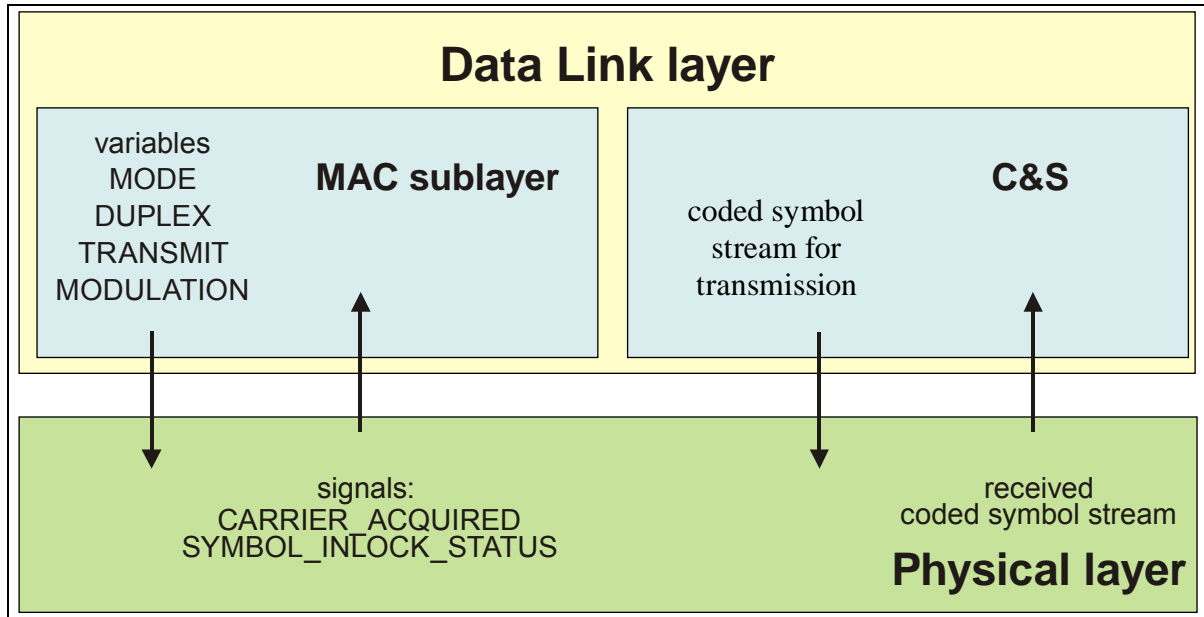

Figure 3-1: Control Variables, Signals, and Data Transfers

3.2.1.2 Configuration of the Physical Layer

The establishment of the communications channel depends on the configuration of the following Physical Layer parameters: frequency, polarization, modulation, acquisition, idle sequence, and coded symbol rates, such that common operating characteristics exist in both communicating entities.

The MAC Sublayer sets the local transceiver to the desired physical configuration, under the control of the directives SET TRANSMITTER PARAMETERS and SET RECEIVER PARAMETERS. A SET PL EXTENSIONS directive is the mechanism by which additional Physical Layer parameters defined outside of the Proximity-1 Physical Layer can be enabled or disabled. The format and content of these and other Proximity-1 directives are specified in an annex of reference [3].

3.2.2 TRANSMITTER

3.2.2.1 Operational State of the Transmitter

The operational state of the transmitter shall depend on the state control variables MODE, TRANSMIT, and MODULATION, as shown in table 3-2.

Table 3-2: Control Variables for Transmitter

MODE	TRANSMIT	MODULATION	Transmitter state
<i>inactive</i>	N/A	N/A	<i>off</i>
any value except <i>inactive</i>	<i>off</i>	N/A	<i>off</i>
	<i>on</i>	<i>false</i>	<i>on</i> , radiated output is carrier only
	<i>on</i>	<i>true</i>	<i>on</i> , data modulated onto the radiated carrier

NOTES

- 1 Unless MODE is *inactive*, a change in the value of TRANSMIT signals the Physical Layer to transition the transmitter to *on* or *off*.
- 2 An MIB parameter, Carrier_Only_Duration, is used in the Data Link Layer to control the duration of the carrier-only transmission (TRANSMIT = *on* and MODULATION = *false*).
- 3 When TRANSMIT is *on* and MODULATION is *true*, the Physical Layer receives coded symbols for transmission from the Data Link Layer (C&S Sublayer). The content of the output coded symbols stream is specified in reference [3], which defines an output coded symbols stream FIFO. The data include PLTUs and Idle data, for example in the Acquisition sequence that is sent when transmission commences so that the receiving unit can acquire the signal. The format of Idle data is specified in reference [2].

3.2.3 RECEIVER

3.2.3.1 Operational State of the Receiver

The operational state of the receiver shall depend on the state control variables MODE, DUPLEX, and TRANSMIT, as shown in table 3-3.

Table 3-3: Control Variables for Receiver

MODE	DUPLEX	TRANSMIT	Receiver state
<i>inactive</i>	N/A	N/A	<i>off</i>
any value except <i>inactive</i>	<i>full or simplex receive</i>	N/A	<i>on</i>
	<i>simplex transmit</i>	N/A	<i>off</i>
	<i>half</i>	<i>on</i>	<i>off</i>
	<i>half</i>	<i>off</i>	<i>on</i>

NOTE – The Physical Layer notifies the Data Link Layer (MAC Sublayer) of the status of the received channel, using the signals CARRIER_ACQUIRED and SYMBOL_INLOCK_STATUS. When SYMBOL_INLOCK_STATUS is *true*, the Physical Layer delivers the received coded symbol streams to the Data Link Layer (C&S Sublayer).

3.2.3.2 Acquisition

The receiver shall sweep the frequency channel to which it is assigned in order to acquire carrier lock at an assigned frequency channel.

NOTE – During this process, the receiver first attempts to lock to the carrier.

3.2.3.3 CARRIER_ACQUIRED signal

3.2.3.3.1 The CARRIER_ACQUIRED signal shall notify the MAC Sublayer that the receiver has acquired a carrier signal.

3.2.3.3.2 The CARRIER_ACQUIRED signal shall be set to *true* when the receiver is locked to the received RF signal and *false* when not in lock.

3.2.3.4 SYMBOL_INLOCK_STATUS signal

3.2.3.4.1 The SYMBOL_INLOCK_STATUS signal shall notify the MAC Sublayer that symbol synchronization has been acquired and the received serial symbol stream is being provided to the Data Link Layer.

3.2.3.4.2 The SYMBOL_INLOCK_STATUS signal shall be set to *true* when the receiver is in symbol lock and *false* when the receiver is not in symbol lock.

NOTE – The receiver is considered to be in symbol lock when it is confident that its symbol detection processes are synchronized to the modulated symbol stream and the symbols output are of an acceptable quality for processing by the Data Link Layer.

3.2.3.5 Received Symbol Stream

When `SYMBOL_INLOCK_STATUS` is *true*, the Physical Layer shall deliver the received symbol stream to the C&S Sublayer.

NOTE – Soft symbol decisions with at least three bits quantization are recommended whenever constraints (such as complexity of demodulator) permit.

3.3 CONTROLLED COMMUNICATIONS CHANNEL PROPERTIES

3.3.1 BACKGROUND

This Recommended Standard is designed primarily for use in a Proximity link space environment far from Earth. The radio frequencies selected in this Recommended Standard are designed not to cause interference to radio communication services allocated by the Radio Regulations of the International Telecommunication Union (ITU). It should be noted that particular precautions have to be taken to protect frequency bands allocated to Near Earth Space Research, Deep Space, and Space Research, passive.

The frequencies specified near 430 MHz cannot be used for this purpose in the vicinity of the Earth, and particular precautions have to be taken for equipment testing on Earth. However, by layering appropriately, provision is made to change only the Physical Layer by adding other frequencies to enable the same protocol to be used in near Earth applications; in the latter case a strict compliance with the frequency allocations in the ITU Radio Regulations is mandatory.

3.3.2 UHF FREQUENCIES

3.3.2.1 General

The frequency range for the UHF Proximity-1 links consists of 60 MHz between 390 MHz to 450 MHz with a 30 MHz guard-band between forward and return frequency bands.

3.3.2.2 Frequency Range

3.3.2.2.1 The forward frequency band shall be from 435 to 450 MHz.

3.3.2.2.2 The return frequency band shall be from 390 to 405 MHz.

NOTES

- 1 Annex A of reference [3] defines the SET TRANSMITTER PARAMETERS and SET RECEIVER PARAMETERS directives, which are used to configure the channel assignment for the remote vehicle's transmitter and receiver for Channels 0 through 7. Annex A of reference [3] also defines the SET PL EXTENSIONS directive for Channels 8 through 15.
- 2 The selection of the frequencies is subject to Space Frequency Coordination Group (SFCG) recommendations.

3.3.2.3 Hailing Channel

3.3.2.3.1 For interoperability at UHF, the default hailing channel shall be Channel 1 configured for 435.6 MHz in the forward link and 404.4 MHz in the return link (1348/44*33 turnaround ratio).

NOTE – Enterprise-specific hailing channel frequencies can be defined in the default configuration of the Physical Layer parameters.

3.3.2.3.2 If the Proximity link radio equipment supports only a single channel (i.e., a single forward and return frequency pair), then the hailing channel shall be the same as the working channel (see 1.5.1.2).

3.3.2.3.3 If the Proximity link radio equipment supports multiple channels, then the hailing channel shall be distinct from the working channel.

3.3.2.3.4 After link establishment through hailing is accomplished, transition to the working channel (if available) should be done as soon as possible.

NOTES

- 1 Hailing is an activity used to establish a Proximity link with a remote vehicle. Hailing requires the use of a hailing frequency pair.
- 2 Hailing is bi-directional; i.e., either element can initiate hailing. Hailing is done at a low data rate and therefore is a low bandwidth activity. Channel 1 has been selected to minimize the use of UHF bandwidth.
- 3 Hailing is performed between transceivers that are pre-configured. Therefore it is nominally performed on the hailing channel. However, if transceivers are compatibly configured, hailing can occur on an agreed-to channel. The first generation transceivers are fixed frequency and use Channel 0.
- 4 Subsection 4.2 of reference [3] (MAC Sublayer) provides further details on hailing in the link establishment process. There are various parameters associated with the hailing activity that are defined in the MIB. Annex B of reference [3] defines these enterprise-specific parameters.

3.3.2.4 Single Forward and Single Return Frequency Pairs

NOTE – Forward and return link frequencies may be coherently related or non-coherent.

3.3.2.4.1 The following three additional channels (fixed single forward and return frequency pairs) are defined for Proximity-1 operations:

- a) Channel 0. In the case where the system requires only one return frequency, associated with the forward 437.1 MHz frequency, the return frequency shall be 401.585625 MHz (147/160 turnaround ratio).
- b) Channel 2. In the case where the system requires only one return frequency, associated with the forward 439.2 MHz frequency, the return frequency shall be 397.5 MHz (1325/24*61 turnaround ratio).
- c) Channel 3. In the case where the system requires only one return frequency, associated with the forward 444.6 MHz frequency, the return frequency shall be 393.9 MHz (1313/38*39 turnaround ratio).

3.3.2.4.2 Table 3-4 details Proximity-1 channel assignments 0 through 7.

NOTE – Channels 8 through 15 are defined in the SET PL EXTENSIONS directive (see annex A of reference [3]). The assignment of specific frequencies to these channels is reserved by CCSDS.

Table 3-4: Proximity-1 Channel Assignments 0 through 7 (Frequencies in MHz)

Channel (Ch) Number	Forward (F) Frequency	Return (R)Frequency
0	437.1	401.585625
1	435.6	404.4
2	439.2	397.5
3	444.6	393.9
4	Within 435 to 450	Within 390 to 405
5	Within 435 to 450	Within 390 to 405
6	Within 435 to 450	Within 390 to 405
7	Within 435 to 450	Within 390 to 405

3.3.2.5 Multiple Forward and Multiple Return Frequencies

In the case where there is a need for one or multiple return frequencies paired with one or multiple forward frequencies, the forward frequencies shall be selected from the 435 to 450

MHz band in 20 kHz steps and the return frequencies shall be selected from 390 to 405 MHz in 20 kHz steps. These frequency pairs shall be distinct from the frequency pairs defined in Channels 0 through 7. The forward and return frequency components of Channels 8 through 15 are reserved for this purpose.

NOTE – Forward and return link frequencies may be coherently related or non-coherent.

3.3.3 DISCUSSION—OTHER FREQUENCY BANDS

Other frequency bands are intentionally left unspecified until a user need for them is identified.

NOTE – If such a need arises, users are requested to contact the CCSDS Secretariat at: secretariat@mailman.ccsds.org.

3.3.4 POLARIZATION

Both forward and return links shall operate with Right Hand Circular Polarization (RHCP).

3.3.5 MODULATION

3.3.5.1 The PCM data shall be Bi-Phase-L encoded and modulated directly onto the carrier.

3.3.5.2 Residual carrier shall be provided with modulation index of $60^\circ \pm 5\%$.

3.3.5.3 The symmetry of PCM Bi-Phase-L waveforms shall be such that the mark-to-space ratio is between 0.98 and 1.02.

3.3.5.4 A positive-going signal shall result in an advance of the phase of the radio frequency carrier. For directly modulated Bi-phase-L waveform,

- a) a symbol '1' shall result in an advance of the phase of the radio frequency carrier at the beginning of the symbol interval;
- b) a symbol '0' shall result in a delay.

3.3.6 PROXIMITY-1 RATES

3.3.6.1 Forward and Return Coded Symbol Rates

The Proximity-1 link shall support one or more of the following 13 discrete forward and return values for the coded symbol rate R_{cs} shown in symbols per second: 1000, 2000, 4000, 8000, 16000, 32000, 64000, 128000, 256000, 512000, 1024000, 2048000, 4096000.

NOTE – The correspondence between R_{cs} and R_d can be found in annex A of reference [3]. The data rate R_d is configured using the SET TRANSMITTER PARAMETERS, SET RECEIVER PARAMETERS and SET PL EXTENSIONS directives defined in annex A of reference [3]; the coded symbol rate R_{cs} is set according to the set value of R_d and to the selected coding option.

3.3.6.2 Short Term Channel Symbol Rate Stability

Each channel symbol period, as measured at the output of the transmitter, shall differ by no more than 1% from the channel symbol period corresponding to the Proximity-1 channel symbol rate in use.

3.3.6.3 Channel Symbol Rate Offset

Generated channel symbol rate, measured over an interval greater than 10000 symbol periods, shall differ less than 0.1% from the defined Proximity-1 channel symbol rates as measured at the output of the transmitter.

3.4 PERFORMANCE REQUIREMENTS

3.4.1 CARRIER FREQUENCY STABILITY REQUIREMENTS

3.4.1.1 The long-term oscillator stability (over the life of the mission) including all effects and over all operating conditions shall be 10 ppm.

3.4.1.2 The short-term oscillator stability over 1 minute shall be 1 ppm.

3.4.2 RESIDUAL AMPLITUDE MODULATION

Residual amplitude modulation of the phase modulated RF signal shall be less than 2% RMS.

3.4.3 NON-COHERENT MODE CARRIER PHASE NOISE

In non-coherent mode, the minimum specification for the oscillator phase noise at 437.1 MHz shall be limited by the template shown in figure 3-2.

NOTE – The figure shows normalized power in dBc (where dBc refers to the power relative to the carrier power) vs. frequency offset from the carrier in Hz.

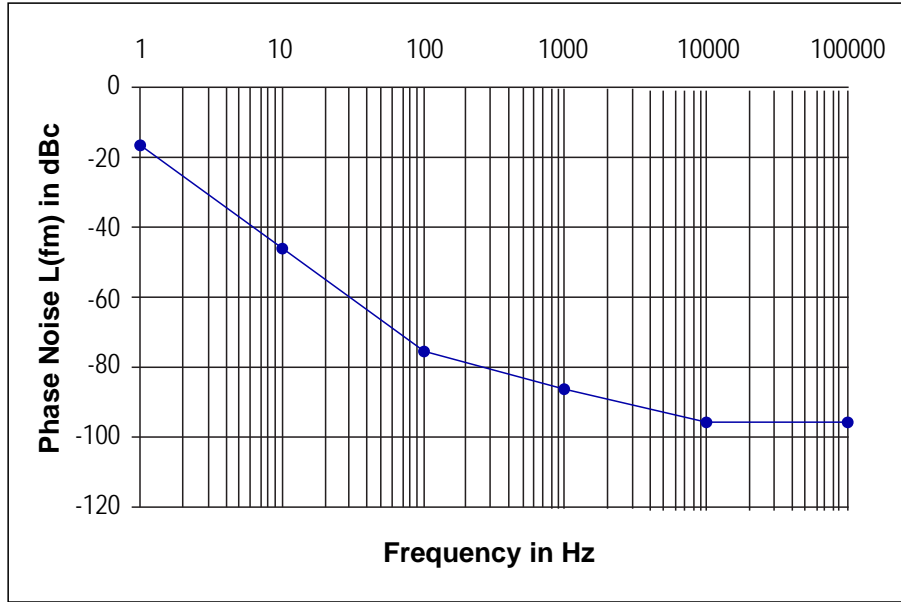
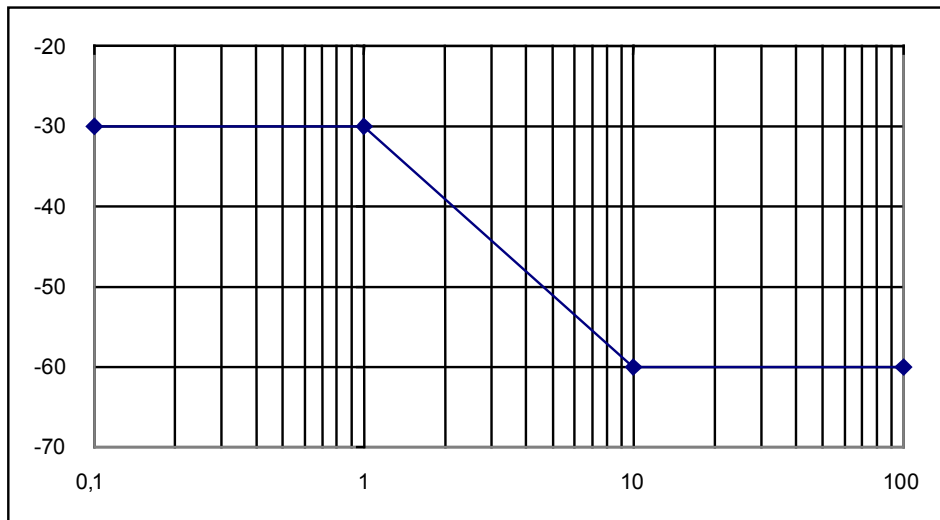

Figure 3-2: Oscillator Phase Noise

3.4.4 DISCRETE SPURIOUS SPECTRAL LINES

The discrete spurious spectral lines of the transmit RF signal shall be limited by the template shown in the figure 3-3.

NOTE – The figure shows normalized power in dBc vs. normalized frequency $(f-f_c)/A$ (where $A = 2 \cdot R_{cs}$, $f_c =$ carrier frequency). The factor of 2 is due to the use of Bi-phase-L waveforms.



**Figure 3-3: Discrete Spurious Spectral Lines Template for the Transmitter
(Normalized Power in dBc vs. Normalized Frequency: $(f-f_c)/A$)**

3.4.5 DOPPLER TRACKING AND ACQUISITION REQUIREMENTS

3.4.5.1 UHF Frequencies

For the UHF frequencies specified in this Recommended Standard, the applicable Doppler requirements shall be as follows.

- a) Doppler frequency range: ± 10 kHz;
- b) Doppler frequency rate:
 - 1) 100 Hz/s (non-coherent mode),
 - 2) 200 Hz/s (coherent mode).

NOTES

- 1 The Doppler frequency rate does not include the Doppler rate required for tracking canister or worst-case spacecraft-to-spacecraft cases.
- 2 The Doppler acquisition and tracking requirements imposed on any of the network elements are specified according to radio frequencies employed on the link.
- 3 The type of Proximity Radio Equipment (table 3-1) and the vehicle type in which it resides (e.g., orbiter, lander) will determine the applicability of capturing Doppler Measurements.
- 4 The requirement applies to the RF interface between all E1 and E2 elements. In the case of the coherent RF interface between E2c elements the effect of the coherent turnaround ratio of the responding element has to be considered.

3.4.5.2 Discussion—Other Frequency Bands

Other frequency bands requirements are intentionally left unspecified until a user need for them is identified.

NOTE – If such a need arises, users are requested to contact the CCSDS Secretariat at: secretariat@mailman.ccsds.org.

ANNEX A

PROTOCOL IMPLEMENTATION CONFORMANCE STATEMENT PROFORMA

(NORMATIVE)

A1 INTRODUCTION

A1.1 OVERVIEW

This annex provides the Protocol Implementation Conformance Statement (PICS) Requirements List (RL) for an implementation of *Proximity-1 Space Link Protocol—Physical Layer* (CCSDS 211.1-B-4). The PICS for an implementation is generated by completing the RL in accordance with the instructions below. An implementation claiming conformance must satisfy the mandatory requirements referenced in the RL.

The RL support column in this annex is blank. An implementation's completed RL is called the PICS. The PICS states which capabilities and options have been implemented. The following can use the PICS:

- the implementer, as a checklist to reduce the risk of failure to conform to the standard through oversight;
- a supplier or potential acquirer of the implementation, as a detailed indication of the capabilities of the implementation, stated relative to the common basis for understanding provided by the standard PICS proforma;
- a user or potential user of the implementation, as a basis for initially checking the possibility of interworking with another implementation (it should be noted that, while interworking can never be guaranteed, failure to interwork can often be predicted from incompatible PICSes);
- a tester, as the basis for selecting appropriate tests against which to assess the claim for conformance of the implementation.

A1.2 ABBREVIATIONS AND CONVENTIONS

The RL consists of information in tabular form. The status of features is indicated using the abbreviations and conventions described below.

Item Column

The item column contains sequential numbers for items in the table.

Feature Column

The feature column contains a brief descriptive name for a feature. It implicitly means ‘Is this feature supported by the implementation?’

Status Column

The status column uses the following notations:

M	mandatory.
O	optional.
O.<n>	optional, but support of at least one of the group of options labeled by the same numeral <n> is required.
C	conditional.
C<n>	conditional on ‘C<n>:’ predicate below table.

Support Column Symbols

The support column is to be used by the implementer to state whether a feature is supported by entering Y, N, or N/A, indicating:

Y	Yes, supported by the implementation.
N	No, not supported by the implementation.
N/A	Not applicable.

The support column should also be used, when appropriate, to enter values supported for a given capability.

A1.3 INSTRUCTIONS FOR COMPLETING THE RL

An implementer shows the extent of compliance to the Recommended Standard by completing the RL; that is, the state of compliance with all mandatory requirements and the options supported are shown. The resulting completed RL is called a PICS. The implementer shall complete the RL by entering appropriate responses in the support or values supported column, using the notation described in A1.2. If a conditional requirement is inapplicable, N/A should be used. If a mandatory requirement is not satisfied, exception information must be supplied by entering a reference X_i , where i is a unique identifier, to an accompanying rationale for the noncompliance.

A2 PICS PROFORMA FOR PROXIMITY-1 SPACE LINK PROTOCOL—PHYSICAL LAYER (CCSDS 211.1-B-4)

A2.1 GENERAL INFORMATION

A2.1.1 Identification of PICS

Date of Statement (DD/MM/YYYY)	
PICS serial number	
System Conformance statement cross-reference	

A2.1.2 Identification of Implementation Under Test (IUT)

Implementation name	
Implementation version	
Special Configuration	
Other Information	

A2.1.3 Identification of Supplier

Supplier	
Contact Point for Queries	
Implementation Name(s) and Versions	
Other information necessary for full identification, e.g., name(s) and version(s) for machines and/or operating systems;	
System Name(s)	

A2.1.4 Identification of Specification

CCSDS 211.1-B-4	
Have any exceptions been required?	Yes [] No []
<p>NOTE – A YES answer means that the implementation does not conform to the Recommended Standard. Non-supported mandatory capabilities are to be identified in the PICS, with an explanation of why the implementation is non-conforming.</p>	

A2.2 REQUIREMENTS LIST

Table A-1: Major Capabilities

Item	Description	Reference	Status	Values Allowed	Support/Values Implemented
1.1	Radio equipment category E1	table 3-1	O.1		
1.2	Radio equipment category E2n	table 3-1	O.1		
1.3	Radio equipment category E2c	table 3-1	O.1		
1.3.1	Transmit/receive frequency coherency capability	3.1.2	C1 (note 1)		
1.4	Radio equipment category E2d	table 3-1	O.1		
2.1	Transmitter	3.2.2	M		
2.2	Receiver	3.2.3	C2		
3.1	Frequency Range (MHz)	3.3.2.2	M	Forward: from 435 to 450; Return: from 390 to 405	
3.2	Hailing channel	3.3.2.3	M (note 2)	Channel 1, Channel 0, Channel N with N=2, 3, .. 15	
3.3	Working channel(s)	3.3.2.4, 3.3.2.5	M (note 3)	Channel 0 .. 15	
3.3.1	Forward and return link frequencies for channels 4, 5, .. 15 (MHz)	3.3.2.5	M	Forward: from 435 to 450 in 20 kHz steps; Return: from 390 to 405 in 20 kHz steps	
4	Polarization	3.3.4	M	Right Hand Circular	
5	Modulation	3.3.5	M	Bi-Phase-L	

CCSDS RECOMMENDED STANDARD FOR PROXIMITY-1 SPACE LINK PROTOCOL—
PHYSICAL LAYER

Item	Description	Reference	Status	Values Allowed	Support/Values Implemented
6.1	Forward coded symbol rates (symbols/s)	3.3.6.1	M (note 4)	1000, 2000, 4000, 8000, 16000, 32000, 64000, 128000, 256000, 512000, 1024000, 2048000, 4096000	
6.2	Return coded symbol rates (symbols/s)	3.3.6.1	M (note 4)	1000, 2000, 4000, 8000, 16000, 32000, 64000, 128000, 256000, 512000, 1024000, 2048000, 4096000	
6.3	Short Term Channel Symbol Rate Stability	3.3.6.2	M	≤ 1%	
6.4	Channel Symbol Rate Offset	3.3.6.3	M	< 0.1%	
7	Performance Requirements	3.4	M		

O.1: Support for one of these categories must be indicated.

C1: IF (Category = E2c) THEN M ELSE O.

C2: IF (Radio equipment category NOT E1) THEN M ELSE N/A.

NOTES

- 1 Mandatory for link elements in category E2c (table 3-1), for which range and range-rate measurements are needed.
- 2 Channel 1 is recommended; Channel 0 is used by legacy systems; Channel N is to be used by radios with only one channel (for hailing and working) or if agreed to.
- 3 The working channel has to be the same as the hailing channel for radios with only one channel.
- 4 Support for at least one of the indicated 13 discrete values for the coded symbol rate is mandatory.

ANNEX B

SECURITY, SANA, AND PATENT CONSIDERATIONS

(INFORMATIVE)

B1 SECURITY CONSIDERATIONS

B1.1 INTRODUCTION

The security concern involves radio frequency jamming of the forward and/or return link signal. Jamming of the signal could lead to the total loss of data, and potential navigation errors if Doppler tracking is disrupted.

B1.2 SECURITY CONCERNS WITH RESPECT TO THE CCSDS DOCUMENT

The forward and return link signals are vulnerable to jamming, although there are several mitigating factors. The forward signal cannot be transmitted from Earth since the currently specified channels are reserved by ITU to other services on the Earth surface. A deliberate attempt at jamming the forward signal in violation of the ITU regulations would disrupt a very large number of terrestrial links in light of the difference in distances involved between a terrestrial user and a Proximity-1 user on Mars. Concerning the return signal (received by the orbiter in a deep space scenario), there is limited availability of equipment capable of generating enough uplink power to effectively jam the spacecraft receiver at interplanetary distances.

B1.3 POTENTIAL THREATS AND ATTACK SCENARIOS

Jamming of the signal could result in the loss of data or of Doppler measurements. During a critical maneuver (e.g., probe landing on Mars), jamming could cause uncertainty in the lander trajectory.

B1.4 CONSEQUENCES OF NOT APPLYING SECURITY TO THE TECHNOLOGY

While these security issues are of concern, they are out of scope with respect to this document.

Jamming denies all communications, and protection must be accomplished by Physical-Layer techniques such as spread spectrum and/or frequency hopping. This problem is somewhat mitigated by the amount of power and the size of antennas needed to communicate with the spacecraft, or by the need of having a jamming source in Mars orbit.

B2 SANA CONSIDERATION

The current issue of this Recommended Standard does not require any action from SANA.

B3 PATENT CONSIDERATIONS

No patents are known to apply to this Recommended Standard.

ANNEX C

INFORMATIVE REFERENCES

(INFORMATIVE)

- [C1] *Proximity-1 Space Link Protocol—Rationale, Architecture, and Scenarios*. Issue 2. Report Concerning Space Data System Standards (Green Book), CCSDS 210.0-G-2. Washington, D.C.: CCSDS, December 2013.
- [C2] *TM Synchronization and Channel Coding*. Issue 2. Recommendation for Space Data System Standards (Blue Book), CCSDS 131.0-B-2. Washington, D.C.: CCSDS, August 2011.
- [C3] *Radio Frequency and Modulation Systems—Part 1: Earth Stations and Spacecraft*. Issue 22. Recommendation for Space Data System Standards (Blue Book), CCSDS 401.0-B-22. Washington, D.C.: CCSDS, January 2013.

ANNEX D

ABBREVIATIONS AND ACRONYMS

(INFORMATIVE)

C&S	Coding and Synchronization
CRC	Cyclic Redundancy Check
FSK	Frequency-Shift Keying
ITU	International Telecommunication Union
MAC	Medium Access Control
MIB	Management Information Base
OSI	Open Systems Interconnection
PCM	Pulse-Code Modulation
PLTU	Proximity Link Transmission Unit
PSK	Phase-Shift Keying
R_{chs}	channel symbol rate
R_{cs}	coded symbol rate
R_d	data rate
RHCP	Right Hand Circular Polarization
SANA	Space Assigned Numbers Authority
SFCG	Space Frequency Coordination Group